



To Boldly Go

Part 10 of A Song of Fates

A strange visitor has arrived in Thentia. Both the Council of Mages and Merchants are interested in speaking with him as things in Thentia have been a bit gloom. Once his business is concluded in town he'll need an escort back home to the ... Feywild.

A 2-Hour Adventure for 5th-10th Level Characters



John Sedlack
Author

Adventure Code: DDAL-CCC-Tarot02-03

Optimized For: APL 8

Version: 1.4

Development and Editing: Joshua Clark, Blake Jones, Ian Priddy, Todd Smart, Ariel Thomas, Brian Treitler

Organized Play: Chris Lindsay

D&D Adventurers League Wizards Team: Adam Lee, Chris Lindsay, Mike Mearls, Matt Sernett

D&D Adventurers League Administrators: Lysa Chen, Bill Benham, Travis Woodall, Claire Hoffman, Greg Marks, Alan Patrick

DUNGEONS & DRAGONS, D&D, Wizards of the Coast, Forgotten Realms, the dragon ampersand, *Player's Handbook*, *Monster Manual*, *Dungeon Master's Guide*, D&D Adventurers League, all other Wizards of the Coast product names, and their respective logos are trademarks of Wizards of the Coast in the USA and other countries. All characters and their distinctive likenesses are property of Wizards of the Coast. This material is protected under the copyright laws of the United States of America. Any reproduction or unauthorized use of the material or artwork contained herein is prohibited without the express written permission of Wizards of the Coast.

©2017 Wizards of the Coast LLC, PO Box 707, Renton, WA 98057-0707, USA. Manufactured by Hasbro SA, Rue Emile-Boéchat 31, 2800 Delémont, CH. Represented by Hasbro Europe, 4 The Square, Stockley Park, Uxbridge, Middlesex, UB11 1ET, UK

Introduction

Welcome to *Adventure Name*, a D&D Adventurers League™ adventure, part of the official D&D Adventurers League™ organized play system.

The City of Thentia faces food shortages, bandits, storms, and yet another threat that very few are aware of. Items of supposedly great power are hidden throughout the city and many quietly strive to acquire them.

This adventure is designed for **three to seven 5th-10th level characters** and is optimized for **five characters with an average party level (APL) of 8**. Characters outside this level range cannot participate in this adventure.

Adjusting This Adventure

This adventure provides suggestions in making adjustments for smaller or larger groups, characters of higher or lower levels, and characters that are otherwise a bit more powerful than the adventure is optimized for. You're not bound to these adjustments; they're here for your convenience.

To figure out whether you should consider adjusting the adventure, add up the total levels of all the characters and divide the total by the number of characters (rounding .5 or greater up; .4 or less down). This is the group's APL. To approximate the **party strength** for the adventure, consult the following table.

Determining Party Strength

Party Composition	Party Strength
3-4 characters, APL less than	Very weak
3-4 characters, APL equivalent	Weak
3-4 characters, APL greater than	Average
5 characters, APL less than	Weak
5 characters, APL equivalent	Average
5 characters, APL greater than	Strong
6-7 characters, APL less than	Average
6-7 characters, APL equivalent	Strong
6-7 characters, APL greater than	Very strong

Some encounters may include a sidebar that offers suggestions for certain party strengths. If a particular recommendation is not offered or appropriate for your group, you don't have to make adjustments.

Before Play at the Table

Before you start play, consider the following:

- Read through the adventure, taking notes of anything you'd like to highlight or remind yourself of while running the adventure, such as a way you'd like to portray an NPC or a tactic you'd like to use in a combat. Familiarize yourself with the adventure's appendices and handouts.
- Gather any resources you'd like to use to aid you in running this adventure--such as notecards, a DM screen, miniatures, and battlemaps.
- Ask the players to provide you with relevant character information, such as name, race, class, and level; passive Wisdom (Perception), and anything specified as notable by the adventure (such as backgrounds, traits, flaws, etc.)

Playing the Dungeon Master

You have the most important role—facilitating the enjoyment of the game for the players. You provide the narrative and bring the words on these pages to life.

To facilitate this, keep in mind the following:

You're Empowered. Make decisions about how the group interacts with the adventure; adjusting or improvising is encouraged, so long as you maintain the adventure's spirit. This doesn't allow you to implement house rules or change those of the Adventurers League, however; they should be consistent in this regard.

Challenge Your Players. Gauge the experience level of your **players** (not the characters), try to feel out (or ask) what they like in a game, and attempt to deliver the experience they're after. Everyone should have the opportunity to shine.

Keep the Adventure Moving. When the game starts to get bogged down, feel free to provide hints and clues to your players so they can attempt to solve puzzles, engage in combat, and roleplay interactions without getting too frustrated over a lack of information. This gives players "little victories" for figuring out good choices from clues. Watch for stalling—play loses momentum when this happens. At the same time, make sure that the players don't finish too early; provide them with a full play experience.

Adventure Primer

Events from a Time Past

Many an adventurer has heard of the Deck of Many Things, a Deck in which you pulled cards and received either great treasure, or terrible ruin. Few scholars have tales of a special Deck. It is said to be a mix of the original Deck and ancient Vistani magic, and called the Tarot Cards of Fate. Each card is unique in nature, and said to be even more powerful than a traditional Deck, it is long thought Fate had decreed the Cards separated, and each lost to antiquity.

With events such as the Spellplague, unleashing arcane chaos and the Blue Fire, loosening the magical shackles and the return of parts of Faerun from the Demiplane of Dread, rumors of Cards promising great power have been emerging throughout the lands.

Currently known to a select few greater powers, who have access to great libraries or performed epic rituals of divination, they have become aware of an ancient Prophecy that tell of great power gained by those who have acquired the most Tarot Cards. Quickly, they sent mortal agents spread across the Moonsea and Sword Coast searching for any hints and obscure lore or legend that would reveal the hiding places of the Tarot Cards of Fate, intent on acquiring as many as possible. As more knowledge of the Cards leaks out, a mad race to acquire their power will truly commence.

Events in a Time Present

Famine. Infection. Unrest. These are words on every citizens tongue. Thentia has not seen such dire times. Half the population lies in the Forbidden Zone while the other starves outside of it. Meanwhile planar magic has seeped into Thar and with it, strange occurrences.

The Magician card has awoken and a sense of “can-do” attitude has overcome the city leaders. They plan on holding a Council of Fates to determine the future of Thentia.

Some believe the infection needs to be taken care of, while others want to help those who are still healthy. And as the leaders clash, it is the people who suffer.

Location and NPC Summary

The following NPCs and locations feature prominently in this adventure. Each NPC and location should have an entry with a

phonetic pronunciation and one-three sentences describing them.

Xanfis (ZAAN-fee). Xanfis is an Eladrin emissary and also a Blessed of Corellon. Their mood is ever changing, but is generally good willed toward the adventurers

Karasht Silverflame. Transmuter Archmage on the Council of Mages. He is sarcastic and short tempered.

Widar Patja (VIE-dar Pat-ya). Widar has invested quite a bit of gold into solving Thentia’s famine issues. His family has been heres since the early days, and he intends for the Patja name to stick around .

Auntie Helena (Hell-en-ah). A Night hag who has been using the magic of the Feywild and the spore infection to perform cruel experiments

Summer Lilly. A farm set up by Widar Patja, to help with the famine in the area

DM Note on Divination Magic

Due to the influence of the revealed Tarot cards, access to divination magic has been obstructed. When cast, the following spells fail and the slot is wasted.

Detect Evil & Good

Identify

Augury

Clairvoyance

Divination

Commune

Contact Other Plane

Scrying

Find the Path

Adventure Overview

The adventure is broken down into 5 parts:

Part 1. Adventurers start of in Thentia and encounter the fortune teller and listen in on the current events of Thentia.

Part 2. The adventurers sit in on the Council of Fates who ask them to investigate Thar while escorting Xanfis home

Part 3a & 3b. Adventurers see just how the spore infection and Abyssal and Feywild incursion have impacted Thar. Each section has a separate encounter. You may run both and treat one as a bonus objective. For “The Magician” story award, players receive the state for the path they choose first

Part 4. Here the planar magic is stronger and the adventurers must navigate a magical maze, before reaching their destination.

Part 5. At the end of the maze, the adventurers find

Auntie Helena performing a cruel experiment on a Treant.

Adventure Hooks

Since the Tarot cards of fate are being revealed one by one, things haven't been the best for Thentia, and as such, there is plenty of work to go around for those looking to make a few extra coin.

Bodyguards. The Council of Mages have asked that you escort an important Emissary back to his home. and protect him along the way.

Fey Flowers. A pocket of Feywild had appeared in Thar outside of Thentia. The Mediciner's Guild wish for you to investigate and collect a sample of flora and fauna.

Coincidence?. With the recent "disturbances" surrounding Thentia, a pocket of Feywild appearing, can't be a coincidence. The Selunites ask you to investigate and see if the two are related.

Part 1. The Mage Pit

Estimated Duration: 15 minutes

The characters are sheltering themselves from the storm in the local watering hole, where they overhear a bit about the current state of the city

General Features

Thentia has the following general features.

Terrain. The City is desolate.

Weather. Heavy rains for the past few days

Light. The Mage pit is lit by sconces of red flickering light from a Continual flame spell.

Smells and Sounds. Rainfall, hushed chatter.

Day five of unrelenting rain, and like most of the citizens of Thentia you find yourself indoors. As thunder roars outside, the rain patters against the roof of The Mage Pit, the local watering hole you have found yourself in. The Mage Pit is famous for being built in the crater left when Thauguran's Tower sprouted legs and walked out of the city. Known for being a favorite amongst Thentia arcane citizens, The Mage Pit is also known for having craft brews from across the realm including Sorcerer's Sweat, Elisande's Goat, Helles-frog and many others.

You would normally expect a place like this to be packed, however it is sparse. And everytime a patron coughs, a silence quickly spreads amongst the hushed chatter. When conversations resume, you can pick up bits and pieces of conversations, most are talking the infection and the quarantine, a few still discuss the previous election and their dislike of the outcome.

An older gentleman approaches your table. "May I take your drink order"

The waiter that approaches is **The Fortune Teller**. Players who have played previous **TAROT** series modules may recognize him. If players realize who he is and ask what he's doing here, he simply replies that with the State of Thentia being what it is, it's a way to make some extra coin.

After a few moments the man returns with your drink sets them down with a coaster. You manage a quick glimpse and notice that the coaster is more retangle than square and has an ornate image on it.

As you remove your drink the image becomes unobscured, the coaster is a tarot card. You look up and the gentleman has a smile across his face. "Would you like to know what those say about your tomorrow and beyond?"

Consult **Appendix: Tarot Reading** and have each player roll a d8 to determine the card, Next have them re-roll to determine if their card was dealt upright or inverted. All players receive the **Touched by Fate Story Award** if they do not already have it.

Players may mingle about the tavern and gain the following information with a **DC10 Persuasion (charisma) or Perception (wisdom) check** from the following patrons:

- Fargrim, the dwarven bartender. Prides himself on his brewing ability, especially Elisande's goat. He's waiting on a delivery of hops from **Widar Patja** that is a few days behind schedule, and he hasn't heard from him.
- Arryk, a half-elf pirate. He's been stuck in Thentia since his ship, *Deceit of the North*, sank in Shipbreaker Bay. (he thought he was a capable captain to navigate it). He's annoyed that the Harbor ward has been quarantined off and he can't access the crew or resources to build a new ship and set sail out of here.
- Ahkt, tiefling sorcerer. He assumes that the adventurers are hitting on him, and claims that he's in loving and committed relationship with Grazz't. He tells the adventurers that Grazz't would never let the fungus infection get so out of hand.
- Vann, a water genasi, he's wearing the holy symbol of Talos around his neck. Vann mentions that there is something off about the storms, but doesn't mind because it pleases Talos.
- Rum, a human male is here because he's been searching for a magical sword that is rumored to be hidden in Thentia. At this point he believes the rumors to be a hoax to keep adventurers in the city spending their hard earned money on accommodations and food.
- Brin, a human female, is in town to meet with **Kianne Amblecrown** at the Spiraling Tower tomorrow. Kianne mentioned to Byrnn that an Eladrin will be joining them to discuss the spore infection in area.

When the party is ready to leave the Mage Pit read the following:

As you gather yourselves a loud crack of thunder echoes outside, as a bright flash of light illuminates the interior of The Mage Pit from the windows. A moment later a young man walks in the door. The staff he carries is adorned with the symbol of Savras at the top. A small puddle forms under him as the rain drips off of his cloak. He lowers his hood as he makes his way towards your group. His face is unusually thin for someone his age. "Hello friends, for those who don't know me, I am Asham Jahla, apprentice to Head Divinator Kianne Amblecrown. She has sent me to extend an invitation to spectate the council meeting, for she says there will be work to do afterwards. The meeting is at the Spiraling Tower at nine bells. Do you accept?"

since Karasht told her to keep an eye on Ash after the events of TAROT 01-05.

Once the PCs are done asking questions, Ash takes his leave. PCs are free to brave the storm and explore Thentia or wait it out in the tavern for the night and go to the meeting first thing in the morning.

If the PCs elect to stay in at the Mage Pit to ride out the storm the cost is 1gp for a single room or 5sp for a double. If everyone elects for a double and you have an odd party number, the odd person out can randomly bunk with one of the other patrons mentioned earlier. From here you can move onto **Part 2**.

If they PCs accept, Ash pulls out a small piece of copper wire that disappears as he mutters a few arcane words. He is casting *Sending* to let **Kianne** know that they party has agreed or declined.

If the party has questions, Ash can impart the following information.

- If asked about the nature of this meeting, Ash says that the leaders of Thentia are meeting to discuss the spore epidemic and food shortages.
- If asked who specifically would be at the meeting, Ash lets them know that Karasht Silverflame and Kianne Amblecrown are representing the Council of mages, newly elected watchlord Aesir Highcastle, Widar Patja will be there making sure the Merchant's guild has a voice, Brackon Thistlethorn from the Riders, and Lilli Miggledy from the Mediciner's guild will be also be in attendance. Kianne also mentioned a guest from a far away land that will be joining who may have insight on what is going on.
- If asked why he looks emaciated, Ash admits that as punishment for accepting help from a Hag patron, Karasht cut back his rations and given that they were already cut because of the shortages he eats just enough to survive.
- If asked about the hag patron, Ash shamefully admits that he accepted help from Granny Patricia and her sisters, Auntie Helena and Auntie Sue when he first started studying. He now dedicates himself fully to the divination arts without their help.

Staff of Savras

Savras is the god of divination and fortune telling whose symbol is crystal ball containing many eyes.

This staff is adorned with the symbol of Savras which unbeknownst to Ash is a Hag's eye used to spy on him and the Council.

The staff radiates divination magic if subjected to a detect magic spell. If questioned about this, Ash believes it was Kianne

Part 2. The Council of Fates

Estimated Duration: 15 minutes

The party sits in on the Council of Fates and must choose who to help.

As the party lies down to rest, choose one character to be subjected to **Auntie Helena's (Night Hag) Nightmare Haunting** and read the following to that player.

The rain starts to settle down to a light patter, becoming a soothing rhythm hitting the roof as you drift into a peaceful sleep. However, **[Character Name]**, this sleep is not peaceful for you as it is the other members of your party. You dream of an empty void with rain falling in rhythm to that outside, the droplets hit your flesh gently when suddenly the drops falling form into skulls being pelted at you. As you look up you see the moon turning into the visage of a purple skinned woman. You try running as your feet turn into gnarled roots securing you to the ground. You slowly become enveloped in bark covered with mushrooms, unable to move, the face comes hurtling at you before turning into a boulder that decimates you into a thousand tiny splinters. You wake up, your bed drenched in sweat, having the worst sleep of your night as you hear the bells of the temple toll eight times.

Nightmare Haunting

While on the Ethereal Plane, the hag magically touches a sleeping humanoid on the Material Plane. A protection from evil and good spell cast on the target prevents this contact, as does a magic circle. As long as the contact persists, the target has dreadful visions. If these visions last for at least 1 hour, the **target gains no benefit from its rest**, and its hit point maximum is reduced by **5 (1d10)**. If this effect reduces the target's hit point maximum to 0, the target dies, and if the target was evil, its soul is trapped in the hag's soul bag. The reduction to the target's hit point maximum lasts until removed by the **greater restoration spell** or similar magic.

Characters have an hour until the council meeting starts, which should leave them enough time to have breakfast and pull themselves together. If the character who was affected by the *Nightmare Haunting* wants to go to the one of the Temples to request spellcasting services they'll have just enough time to do so and make it to the meeting before the doors are closed, but they'll have to skip breakfast or get it to go. Otherwise a party member can cast the requisite spell if available.

When the party sets out for the council meeting read the following:

The rain has let up, as sunshine peeks through the clouds. The streets on the way to the Spiraling tower are muddy and filled with puddles. A wayward child splashes in one of those puddles as her mother shouts in disappointment. It's a pleasant day compared to yesterday.

You eventually arrive at the Spiraling Tower, which as you enter, realize is larger on the inside. Ash is waiting inside for you and leads you towards the viewing gallery of the council chambers, he then takes a seat next to you. Below you see an ornately carved table which looks similar in shape to that of Thentia. At the head of this table is a Fire Genasi with Silver flames for hair. His place setting reads 'Karasht Silverflame: Council of Mages' You see place settings for Brackon Thistlethorn, Kianne Amblecrown, Widar Patja, Lilli Miggedly, and Xanfis. Opposite of Karasht is a place setting for Aesir Highcastle.

As they members go around the table introducing themselves, one creature stands out more so than all the others. Xanfis, the Eladrin. After introductions are made, Karasht stands "Many thanks to you all for joining us, especially our esteemed guest Xanfis, who hopefully can share some insight onto what is happening and can help us stop it"

Roleplaying Xanfis

Xanfis (ZAAN-fee) is a Blessed of Correlon Eladrin. They are beautiful with both masculine and feminine features.. Their emotion (Spring, Summer, Autumn, or Winter) can be whatever you choose.

Spring (Green appearance) - Filled with joy and mischief, they like to beguile others into feeling Joy

Summer (Gold appearance) - Filled with anger, they strike with quickness and force

Autumn (Orange/Red appearance)- Filled with goodwill, they try to defuse situations and abhor violence

Winter (Blue appearance)- Filled with sorrow, they are melancholy and bitter

Quote: "I'm here to do what needs to be done"

The Council of Fates meeting goes on for about two hours before drawing to an end. With all parties talking back and forth about what the greatest need is.

Here's what the meeting boils down to.

- Karasht believes that the solution to the infection lies at the beginning, where the spores were first detected.
- Widar believes that it doesn't matter about where it began if they can't feed those who are healthy. Summer's Lily farm needs to be protected.
- Kianne believes that both arguments have their merits and that fate should decide their actions.

- Aesir wants the infection out of his city and if that means going to the source, than so be it. What good is food if we're all to be consumed by the spores.
- Lilli needs the farm up and running so that the Medicinier's Guild can get the herbs they need to treat the infected.
- Brackon needs more men, quarantining the infected and preventing food riots have put a drain on the rider's resources. They could make do with the man power they have, if one of the two were solved.
- Xanfis remained quiet for most of the meeting, however they chimed up towards the end to let the council know that a demonic influence was detected in their home in the Feywild, and with the pocket that has appeared they believe it may have seeped into the Material Plane.

As the meeting has drawn to an end, Karasht looks up to the viewing area, to your party.

"Adventurers you are the God Pawns, ... the Fate Changers. Take Xanfis back to the pocket and go to the swamps where the spores were detected"

"No to Summer's Lilly so that you may save our people." interrupts Widar.

Karasht chimes back in "Go to Summer's Lilly or the source, I do not care. Information you bring us will be valuable regardless. Time is of the essence, choose quickly and be on your way."

The characters must choose which path to take, either to the source of the infection (**Part 3a**) or to Summer's Lily farm (**Part 3b**)

The path that the party chooses not to follow, can be run as a bonus objective after the path they choose but before running part 4. Whichever path the party chooses first will award them the corresponding state of the "**The Magician**" story award.

Part 3. To Thar and Beyond

Estimated Duration: 45 minutes

Part 3a. Spore Swamp

Characters see first hand how the spores are affecting creature while encountering a servant of Auntie Helena. This section uses **Map 3a**.

General Features

The swamp has the following general features:

Terrain. Murky brown water covers most of the area. Any plots of land are soft and spongy.

Weather. The air here is hot and humid. It feels like the air is clinging to you

Light. It is perpetual twilight. Purple skies with lots of stars and a full moon and setting sun provide light. .

Smells and Sounds. It is pungent. the area smells of mildew, rot, and decay. Insects can be heard buzzing, the occasional frog croak and splash of water echo

You travel for what feels like hours over the hills of the moorlands, before you lies an expansive swamp seemingly out of nowhere. Behind you is a sprawling forest with no sign of the hills you just traversed. You quickly spot an area with small land masses that you feel may be easier to traverse than the wide expanse of murky brown water that seems to extend forever.

Hidden in the water is **(2) Spore infected Giant Crocodiles and a Banderhobb**. While fully submerged the creatures are considered to have *three-quarters cover granting them a +5 bonus to their AC and Dexterity saving throws* . Once the characters start making their way into the water the creatures sense them and are looking for a meal. Characters that have a *passive perception of 15 or higher* are not surprised. See the sidebar about Spore Infection.

Development

The giant crocodiles are looking for a meal. Once they get an adventurer in their jaws they tried to swim away so they eat in peace. The Banderhobb is out for blood, and will not stop until all the adventurers are dead or it dies trying. See the sidebar about Banderhobbs for more information.

Adjusting this Encounter

Here are some suggestions for adjusting this encounter, according to your group. These are not cumulative.

- **Very Weak:** Replace the **giant crocodiles** with three **Spore infected giant constrictor snakes**

- **Weak:** Remove one **giant crocodile**
- **Strong:** Add a **Spore Infected giant constrictor snake**
- **Very Strong:** Add a **Banderhobb**

Treasure

Gutting the crocodiles requires a successful DC 13 Survival (wisdom) check. In doing so they find gold teeth from a half digested adventurer worth 50gp and five undigested pieces of Jasper covered in bile and mold worth 50gp each.

Spore Infection

Spore infection is largely caused by continued exposure to spores. A one time bite or inhalation is unlikely to cause it to spread. The creatures in the swamp have been surrounded by spore for a time and are covered in fungus as the spores have begun to take over their host.

Creatures afflicted by spores **gain Blindsight** out to 60ft and when the creature is struck by an attack that deals slashing or piercing damage, spores fill the air, heavily obscuring a 5 ft. radius around the creature

Banderhobbs

In the earliest days of the world, a coven of night hags devised a ritual that led to the creation of the first banderhobb. A hag that knows the ritual might be willing to teach it for the right price. Some other dark fey and powerful fiends also know of the process, as do a few mortal mages. Despite its size, a banderhobb makes little noise, moving as silently as the shadows that infuse it. A banderhobb isn't capable of speech, but it can understand orders given to it by its creator and communicates with nearby banderhobbs in a psychic manner. During its brief existence, a banderhobb attempts to carry out the bidding of the one who birthed it. It accomplishes its mission with no concern for the harm it suffers or creates. Its only desire is to serve and succeed. A banderhobb fulfills its duties until its existence ends. When it expires, usually several days after its birth, it leaves behind only tarry goo and wisps of shadow.

DM NOTE: The banderhobb here was summoned by Auntie Helena, the night hag who spied on the adventurers through the hag's eye concealed in Ash's staff of Savras. It's goal is to stop the adventurers so that Auntie Helena can perform a more powerful ritual.

Development

If the characters search the area they find a tree and a small patch of discolored grass on the other side. with a DC 15 Survival (wisdom) check. If they decided to dig at the base of the tree and discolored grass they find

the remains a humanoid skeleton with its heart ripped out.

Development

After the fight, the adventurers should continue to **Part 4**. The party may move onto **Part 3b** as a bonus objective if they choose. They may feel like a rest, but Xanfis urges them to hurry along, for they do not know how much longer this rift will be open. There will be a chance for a short rest in Part 4. If your party took a beating, you may want to guide them to that spot.

XP Award

If the characters find the skeleton, then award each player 50xp.

Story Award

If the players chose this route first award them *The Magician (Inverted)* Story award. This story award is unavailable if they choose Summer's Lily Farm first.

Part 3b. Summer's Lily Farm

Here the characters encounter a bunch of Redcaps who fulfilled Auntie Helena's vendetta against the farm.

This section uses **Map 3b**

General Features

The farm has the following general features:

Terrain. The area has well trimmed grass covered in dew and large stacks of hay.

Weather. The air here is humid and warm.

Light. It is perpetual twilight. Purple skies with lots of stars and a full moon and setting sun provide light.

Smells and Sounds. Rotting straw and flesh, eerily silent

You travel for what feels like hours over the hills of the moorlands. As you crest the hill, you spot your destination, Summer's Lilly. As you approach you notice it is eerily quiet, no sign of any life and upon arriving you see the corpse of some of the farm hands, their blood spilled on the ground. Red mushrooms sprout from these pools. As you come in for a closer look, the moon shines on the mushrooms and they begin to twitch, as a creature that looks like a wizened and undersized gnome with a hunched back and a sinewy frame springs from the earth, while from the hay you hear the clanking of heavy iron boots.

Hidden in the hay stacks is **3 Redcaps**, while another **3 Redcaps** sprout from the bloodstained ground.

Development

The redcaps are out for blood, and will not stop until everyone is slain. See the sidebar about Redcaps for more information.

Adjusting this Encounter

Here are some suggestions for adjusting this encounter, according to your group. These are not cumulative.

- **Very Weak:** Remove the three **Redcaps** that were hiding
- **Weak:** Remove two **Redcaps**
- **Strong:** Add a **Redcap**
- **Very Strong:** Add two **Redcaps**

Treasure

Searching the area the characters find 300gp worth of medicinal herbs that Lilli Miggledy would be interested in, with a DC15 Investigation (intelligence) check they find the bloodstained journal of one of the farmhands inside the barn.

Journal

Taking a quick glance through the journal the characters learn the following:

- About a month ago, an old woman by the name of Helena stopped by the farm looking for work.
- No work was available, so they offered her a bed and hot meal before her travels the next day.
- Most people talked about horrible nightmares the day before.
- Upon her departure she asked them to reconsider as being having her around would be in their best interest, but she was still refused a position.
- The next morning one of the farmhands was found dead in the fields next to sme red mushrooms.
- That night a creature with heavy iron boots started killing everyone.
- The author hid in the barn.
- If you find this please tell Widar that I'm sorry I couldn't

The final pages contains a half written entry and is covered in blood.

Redcaps

At first, new redcaps look like tiny bloodstained mushrooms just pushing their caps out of the soil. When moonlight shines on one of these caps, a creature that looks like a wizened and undersized gnome with a hunched back and a sinewy frame springs from the earth. The creature has a pointed leather cap, pants of similar material, heavy iron boots, and a heavy bladed weapon. From the moment it awakens, a redcap desires only murder and carnage, and it sets out to satisfy these cravings.

Redcaps lack subtlety. They live for direct confrontation and the mayhem of mortal combat. Even if a redcap wanted to be stealthy, its iron boots force it to take ponderous, thunderous steps. When a redcap is near to potential prey, though, it can close the distance quickly and get in a vicious swing of its weapon before the target can react.

Redcaps don't usually operate in groups, but in some circumstances they might be found in the employ of hags and dark mages that know methods to call redcaps out of the Feywild and put them to work as grisly servants.

DM NOTE: Auntie Helena was trying to corner the market on herbs in the region through the use of goblins, but Summer's Lilly put a hamper on her operation. She summoned the Redcaps to take care of the farmers and ensure that they don't cause her any disruptions in her supply chain.

Development

After the fight, the adventurers should continue to **Part 4**. The party may move onto **Part 3a** as a bonus objective if they choose. They may feel like a rest, but Xanfis urges them to hurry along, for they do not know how much longer this rift will be open. There will be a chance for a short rest in Part 4. If your party took a beating, you may want to guide them to that spot.

XP Award

If the characters find the journal, then award each player 50xp.

Story Award

If the players chose this route first award them ***The Magician (Upright)*** Story award. This story award is unavailable if they go to the Spore Swamp first.

Part 4. Which Way to Go

Estimated Duration: 30 minutes

Character's must navigate a looping maze often finding themselves back where they started. This section uses **Map 4**

General Features

The clearing has the following general features:

Terrain. The the ground is covered in grass unless otherwise noted. Thick trees and brambles form a wall around the clearing 50ft into the air.

Weather. The air cool and brisk.

Light. It is perpetual twilight. Purple skies with lots of stars and a full moon and setting sun provide light.

Smells, Sights and Sounds. The area smells of a fresh spring shower. If players try to view the clearing from above all they see is the single clearing and thick forest from horizon to horizon

You travel deeper into Thar and before you is an ever expanding forest, behind you the same. Some of you feel like you've been traveling for hours while some of you it feels like mere moments have passed by. An everlasting twilight permeates the sky, sneaking in through the thick canopy. You march on and on seemingly in circles before you finally come across a clearing in the forest. This circular clearing has thick walls composed of trees vines and these little flowers that seem to be laughing at you. You notice three exits in addition to the entrance you walked in from.

Character's will be entering in from **Area 1**, see **DM Appendix A: Maze Path**. Use the Map : "The Clearings" for all of the areas as they are identical in size and shape. If characters go through the wrong exit (marked with an X) they appear back at the entrance for area 1, if they go one at a time describe it as taking hours or moments for them and the opposite for the rest of the party.

DM Note

It's very easy for this section to run long, if you're in a time restricted or convention setting you can skip most of the maze. If characters go to the East they find Area 10, to the West they find Area 9, if they go North, they appear where they entered. If time is not a factor, have fun with it, skip some of the clues and let the characters get lost.

Area 1

This is where the characters first enter the clearings, as described in the boxed text.. The only way out of this area is by trial and error.

Area 2

This clearing appears the same as the one you just left the only difference is that there are two logs lying on the ground.

A **DC15 Investigation (Intelligence)** check finds the following written in Sylvan on the underside of the log:

This star leads you home

Characters that head North, end up in **Area 3**

Area 3

Almost instantaneously you find yourself in a clearing littered with small stones.

A **DC10 Investigation (Intelligence) or Perception (Wisdom)** check finds a raven skull with scratches over the eye sockets. If characters get a birds eye view they notice some of the stones form an arrow pointing east.

Area 4

The ground in this clearing is moist and covered with puddles. Mushrooms sprout from the ground

A **DC15 Nature (Intelligence) or Perception (Wisdom)** check notices that to the east (**Area 10**) is lush green grass while to the north (**Area 5**) the grass is dead

Area 5

A lone tree stands in this clearing. it's roosts gnarled, it's bark blackened it has clearly been dead for a time. Etched in Abyssal is the following phrase:

From the beginning of eternity,
To the end of space and time,
I'm the beginning of the end,
And forever last in line.

The answer is the letter E, guiding the party to head east to **Area 6**

Area 6

From death springs new life and as you enter this clearing you see seven small saplings growing in a line from north to south. The smallest sapling is directly in front of you and the largest is near the south exit.

The saplings are growing in a straight line to where the adventurers need to head next. If they go south, they end up in **Area 7**

Area 7

A berry bush is all that occupies this clearing.

A **DC15 Nature (Intelligence)** check reveals that these berries are toxic. Characters who eat a berry must pass a **DC10 Constitution saving throw** or be *poisoned* until their next long rest. The DC increases by 1 for each additional berry that they eat.

A **DC15 Survival (Wisdom)** check reveals that the bush branches are growing north.

The correct path to go is South to **Area 8**, as the bush is growing away from the corruption that is the Night Hag's.

Area 8

Here the grass is dead, the soil, dry and cracked. Even the plant life surrounding the clearing appears dead and decaying. Bodies are strewn about the clearing. Upon closer inspection you realize that it is your own corpse you see lying on the ground.

A regional effect of Auntie Helena is that Intelligent creatures see hallucinations of dead friends, family members, and even themselves littering the hag's realm. Characters must make a **DC14 Wisdom Saving throw** or suffer a level of madness. See the Short term madness sidebar for effects.

A **DC15 Perception (Wisdom)** check notices that the cracks in the ground spell out the following in Common:

As the sun sets, so shall you.

Area 9

Move onto **Part 5: Auntie Helena's Lair**

Area 10

Lush flowers and a pond grace this glade. It is serene, and you feel peaceful and content. Upon closer inspection you see that the pond is shaped like a unicorn's head. The water is crystal clear.

A **DC15 Religion (Intelligence)** check reveals that the unicorn's head is their symbol of Mielikki (see sidebar). Any adventurer brave enough to drink the pond water or go for a quick swim are granted the benefits of a *Short Rest*. The water loses its potency an hour after being removed from the pond.

Mielikki

Known as Our Lady of the Forest, and the Forest Queen, she is the goddess of the forest and the creatures that live within it.

She is said to keep watch over good folk in any forest, no matter how dark or cruel. When children are lost in the woods, people beseech Mielikki to protect them until they are found.

Short Term Madness

d100 Effect (lasts 1d10 minutes)

01–20 The character retreats into his or her mind and becomes *paralyzed*. The effect ends if the character takes any damage.

21–30 The character becomes *incapacitated* and spends the duration screaming, laughing, or weeping.

31–40 The character becomes *frightened* and must use his or her action and movement each round to flee from the source of the fear.

41–50 The character begins babbling and is incapable of normal speech or spellcasting.

51–60 The character must use his or her action each round to attack the nearest creature.

61–70 The character experiences vivid hallucinations and has disadvantage on ability checks.

71–75 The character does whatever anyone tells him or her to do that isn't obviously self-destructive.

76–80 The character experiences an overpowering urge to eat something strange such as dirt, slime, or offal.

81–90 The character is *stunned*.

91–100 The character falls *unconscious*.

Part 5. Auntie Helena's Lair

Estimated Duration: 20 minutes

This section also uses **Map 4**

Twilight overhead, you enter what you hope is the end of this maze. Before you stands a giant tree black twisted bark and gnarled roots, much larger than the one you saw earlier. Opposite the tree lies a table with a book, an odd assortment of items, and large branch that seems to be made of the same wood as the tree, and other trinkets. Before the tree stands a purple skinned woman, reciting some sort of incantation. She pauses... "Hello dearies, have you come to help or be a hindrance?"

Auntie Helena (Night Hag) is there with a corrupted **Treant**. She and her sisters have hidden a Hag's Eye in Ash's Staff of Savras and thus cannot be suprised by the arrival of the adventurers. If the adventures reply with anything other than they're here to help. Auntie Helena cast *Magic Missile* at the speaker and combat begins.

If they offer to help Auntie Helena will placate them for a moment to see how much they have found out out what she's doing and what's been going on around Thentia. She refuses to give up any information that the players don't already know

- Why have you come?
- What do you know of the woad?
- Tell me, what have the cards told you?
- Who are the Ordines? What about the Inevitables?
- My children, how far has the infection spread?
- Do you wish to meet The Lady of Rot and Decay?

After asking about The Lady of Rot and Decay (*Zuggtmoy*), **Auntie Helena** cast *Magic Missile*, targeting the person in the front of the marching order or the one who was speaking.

Development

Auntie Helena cannot be killed, once she drops below 50 hit points she disappears and read the following, interrupting initiative:

As your hit lands on Auntie Helena, she stares at you, the hatred of a thousands suns burns in her eyes. You feel her peering into your soul learning your deepest fears. "You haven't seen the last of me dearie."

Once Auntie Helena is gone, go are the lair actions. If a creature is on the demiplane when she leaves they're immediately teleported back.

Adjusting this Encounter

Here are some suggestions for adjusting this encounter, according to your group. These are not cumulative.

- **Very Weak:** Remove the *Animate Trees ability* from the **Treant** and the Treant only has 100 hit points
- **Weak:** Remove the *Animate Trees ability* from the **Treant**
- **Strong:** The **Treant** has already used its *Animate Trees ability* to create **one** additional trees
- **Very Strong:** The **Treant** has already used its *Animate Trees ability* to create **two** additional trees

Lair Actions

On initiative count 20 (losing initiative ties), Auntie Helena can take a lair action to cause one of the following effects, but can't use the same effect two rounds in a row:

- Until initiative count 20 on the next round, the hag can pass through solid walls, doors, ceilings, and floors as if the surfaces weren't there.
- One creature the hag can see within 120 feet of her must succeed on a DC 15 Charisma saving throw or be banished to a prison demiplane. To escape, the creature must use its action to make a Charisma check contested by the hag's. If the creature wins, it escapes the demiplane. Otherwise, the effect ends on initiative count 20 on the next round. When the effect ends, the creature reappears in the space it left or in the nearest unoccupied space if that one is occupied.
- The hag targets up to three creatures that she can see within 60 feet of her. Each target must succeed on a DC 15 Constitution saving throw or be flung up to 30 feet through the air. A creature that strikes a solid object or is released in midair takes 1d6 bludgeoning damage for every 10 feet moved or fallen.

Zuggtmoy

The Demon Queen of Fungi, Lady of Rot and Decay, *Zuggtmoy* is an alien creature whose only desire is to infect the living with spores, transforming them into her mindless servants and, eventually, into decomposing hosts for the mushrooms, molds, and other fungi that she spawns.

Helena's notebook

Taking a quick glance through the notebook the characters learn the following:

- Through torturing the Treant, Helena learned that a Wood Woad made a pact with *Zuggtmoy*.
- The woad can control those afflicted with the spore disease.
- "Control the heart, control the creatures"

- Unable to find this woad, Helena set out to corrupt the Treant she had been torturing
- She believed that she could sacrifice the Treant to Zuggtmoy in exchange for the power of the heart.
- The creature has to be a willing sacrifice for the ritual to work so she set out to corrupt the Treant to do her bidding
- The influence of the Feywild and the Abyss, strengthened her connection and powers
- “Stronger Heart = Stronger Control = Usurp G.P.”

Treasure

On the table is Auntie Helena’s wand (Wand of Paralysis), a trinket from the PHB trinket table for each character, a *spell scroll of Blight*, and potion supplies that the mage council will pay 300gp for.

Conclusion

Xanfis turns to you. “Thank you my friends, I feel this rift starting to subside. The information we gathered here will be most valuable to the leaders of my community as well as yours. I cannot repay you enough for helping me return home. Hurry out before the rift is completely gone. Follow me North and then you must go South” Xanfis then runs through the Northern exit. Following you end back in the clearing with the laughing flowers. Following Xanfis’ instructions you turn about and go through the south exit you just entered from and find yourselves on the outskirts of Thentia.

Heading back to the Spiraling Tower, You see Karasht. “Gone 30 minutes and you’ve already back. Either you’re the greatest adventures the world has ever known or you’ve lost Xanfis” He turns to a nearby Aarakocra. “Soria, see if you can’t fly over the city and find our friend.” She nods and walks off.

Development

If the player’s relay the information of what has transpired, Karasht offers to buy the potion ingredients from them. After paying them he storms off, his silver flame hair glowing brighter, screaming for Ash.

Treasure

Before parting Xanfis hands you a pouch containing four 500gp diamonds suitable for a *Raise Dead spell*.

Rewards

Make sure players note their rewards on their adventure log sheets. Give your name and DCI number (if applicable) so players can record who ran the session.

Experience

Total up all combat experience earned for defeated foes, and divide by the number of characters present in the combat. For non-combat experience, the rewards are listed per character.

Combat Awards

Name of Foe	XP Per Foe
Giant Crocodile	1800
Giant Constrictor Snake	450
Banderhobb	1,800
Redcap	700
Treant	5000
Auntie Helena (Night Hag)	1800

Non-Combat Awards

Task or Accomplishment	XP Per Character
Finding the woad's skeleton	50
Finding the farmhand's Journal	50

The **minimum** total award for each character participating in this adventure is **4,500 experience points**.

The **maximum** total award for each character participating in this adventure is **6,000 experience points**.

Treasure

The characters receive the following treasure, divided up amongst the party. Treasure is divided as evenly as possible. Gold piece values listed for sellable gear are calculated at their selling price, not their purchase price.

Treasure Awards

Item Name	GP Value
Council Payment	500gp
Crocodile Findings	300gp
Potion Ingredients	300gp
Xanfis' gift	2000gp

Consumable magic items should be divided up however the group sees fit. If more than one character is interested in a specific consumable magic item, the

DM can determine who gets it randomly should the group be unable to decide.

Permanent magic items are divided according to a system detailed in the *D&D Adventurers League Dungeon Master's Guide*.

Auntie Helena's Wand (Wand of Paralysis)

Wand, rare (requires attunement by a spellcaster)

This item can be found in the *Dungeon Master's Guide*. The prickly gnarled piece of the corrupted Treant requires a drop of blood to activate. When a creature fails their saving throw, they envision themselves turning into a twisted, rotted tree. **Player Handout 1**.

Scroll of Blight

4th level spell scroll, rare

This spell can be found in the *Player's Handbook*.

Story Awards

During the course of this adventure, the characters may earn the following story award:

Touched by Fate Many Powers circle around Thentia, and the Moonsea searching for lost magical artifacts. For whatever reason, the Fates have chosen you to be involved. More information can be found in **Player Handout 2**.

The Magician :

(Upright) You listened to Widar's plea and decided to investigate Summer's Lilly. No doubt your skills will be needed in the future to help with what you saw. More information can be found in **Player Handout 2**.

(Inverted) You thought it best to listen to Karasht and head to where the spores were most concentrated. Believing that you can overcome anything, you made a decision without hesitation. More information can be found in **Player Handout 2**.

Renown

Each character receives **one renown** at the conclusion of this adventure.

Downtime

Each character receives **five downtime days** at the conclusion of this adventure.

DM Reward

In exchange for running this adventure, you earn DM Rewards as described in the *D&D Adventurers League Dungeon Master's Guide* (ALDMG).

Appendix. Monster/NPC Statistics

Auntie Helena (Night Hag)

Medium fiend, neutral evil

Armor Class 17 (natural armor)

Hit Points 112 (15d8 + 45)

Speed 30 ft.

STR	DEX	CON	INT	WIS	CHA
18 (+4)	15 (+2)	16 (+3)	16 (+3)	14 (+2)	16 (+3)

Skills Deception +7, Insight +6, Perception +6, Stealth +6

Damage Resistances cold, fire; bludgeoning, piercing, and slashing from non magical attacks that aren't silvered

Condition Immunities charmed

Senses darkvision 60 ft., passive Perception 16

Languages Abyssal, Common, Infernal, Primordial, Sylvan

Challenge 5 (1,800 XP)

Innate Spellcasting. The hag's innate spellcasting ability is Charisma (spell save DC 14, +6 to hit with spell attacks). She can innately cast the following spells, requiring no material components:

At will: detect magic, magic missile

2/day each: plane shift (self only), ray of enfeeblement, sleep

Magic Resistance. The hag has advantage on saving throws against spells and other magical effects.

Actions

Claws (Hag Form Only). Melee Weapon Attack: +7 to hit, reach 5 ft., one target. Hit: 13 (2d8 + 4) slashing damage.

Change Shape. The hag magically polymorphs into a Small or Medium female humanoid, or back into her true form. Her statistics are the same in each form. Any equipment she is wearing or carrying isn't transformed. She reverts to her true form if she dies.

Etherealness. The hag magically enters the Ethereal Plane from the Material Plane, or vice versa. To do so, the hag must have a heartstone in her possession.

Nightmare Haunting (1/Day). While on the Ethereal Plane, the hag magically touches a sleeping humanoid on

the Material Plane. A protection from evil and good spell cast on the target prevents this contact, as does a magic circle. As long as the contact persists, the target has dreadful visions. If these visions last for at least 1 hour, the target gains no benefit from its rest, and its hit point maximum is reduced by 5 (1d10). If this effect reduces the target's hit point maximum to 0, the target dies, and if the target was evil, its soul is trapped in the hag's soul bag. The reduction to the target's hit point maximum lasts until removed by the greater restoration spell or similar magic

Lair Actions

On initiative count 20 (losing initiative ties), Auntie Helena can take a lair action to cause one of the following effects, but can't use the same effect two rounds in a row:

- Until initiative count 20 on the next round, the hag can pass through solid walls, doors, ceilings, and floors as if the surfaces weren't there.
- One creature the hag can see within 120 feet of her must succeed on a DC 15 Charisma saving throw or be banished to a prison demiplane. To escape, the creature must use its action to make a Charisma check contested by the hag's. If the creature wins, it escapes the demiplane. Otherwise, the effect ends on initiative count 20 on the next round. When the effect ends, the creature reappears in the space it left or in the nearest unoccupied space if that one is occupied.
- The hag targets up to three creatures that she can see within 60 feet of her. Each target must succeed on a DC 15 Constitution saving throw or be flung up to 30 feet through the air. A creature that strikes a solid object or is released in midair takes 1d6 bludgeoning damage for every 10 feet moved or fallen.

Banderhobb

Large monstrosity, neutral evil

Armor Class 15 (natural armor)

Hit Points 84 (8d10 + 40)

Speed 30ft

STR	DEX	CON	INT	WIS	CHA
20 (+5)	12 (+1)	20 (+5)	11 (+0)	14 (+2)	8 (-1)

Skills Athletics +8, Stealth +7

Condition Immunities Charmed, Frightened

Senses Darkvision 120 ft., Passive Perception 12

Languages Common understands and the languages of its creator, but can't speak

Challenge 5 (1,800 XP)

Resonant Connection. If the banderhobb has even a tiny piece of a creature or an object in its possession, such as a lock of hair or a splinter of wood, it knows the most direct route to that creature or object if it is within 1 mile of the banderhobb.

Shadow Stealth. While in dim light or darkness, the banderhobb can take the Hide action as a bonus action

Actions

Bite. Melee Weapon Attack: +8 to hit, reach 5 ft., one target. Hit: 22 (5d6 + 5) piercing damage, and the target is grappled (escape DC 15) if it is a Large or smaller creature. Until this grapple ends, the target is restrained, and the banderhobb can't use its bite attack or tongue attack on another target.

Tongue. Melee Weapon Attack: +8 to hit, reach 15 ft., one creature. Hit: 10 (3d6) necrotic damage, and the target must make a DC 15 Strength saving throw. On a failed save, the target is pulled to a space within 5 feet of the banderhobb, which can use a bonus action to make a bite attack against the target.

Swallow. The banderhobb makes a bite attack against a Medium or smaller creature it is grappling. If the attack hits, the creature is swallowed, and the grapple ends. The swallowed creature is blinded and restrained, it has total cover against attacks and other effects outside the banderhobb, and it takes 10 (3d6) necrotic damage at the start of each of the banderhobb's turns. A creature reduced to 0 hit points in this way stops taking the necrotic damage and becomes stable.

The banderhobb can have only one creature swallowed at a time. While the banderhobb isn't incapacitated, it can regurgitate the creature at any time (no action required) in a space within 5 feet of it. The creature exits prone. If the banderhobb dies, it likewise regurgitates a swallowed creature.

Shadow Step. The banderhobb magically teleports up to 30 feet to an unoccupied space of dim light or darkness that it can see. Before or after teleporting, it can make a bite or tongue attack.

Redcap

Small fey, chaotic evil

Armor Class 13 (natural armor)

Hit Points 45 (6d6 + 24)

Speed 25 ft.

STR	DEX	CON	INT	WIS	CHA
18 (+4)	13 (+1)	18 (+4)	10 (+0)	12 (+1)	9 (-1)

Skills Athletics +6, Perception +3

Senses Darkvision 60 ft., Passive Perception 13

Languages Common, Sylvan

Challenge 3 (700 XP)

Iron Boots. While moving, the redcap has disadvantage on Dexterity (Stealth) checks.

Outsize Strength. While grappling, the redcap is considered to be Medium. Also, wielding a heavy weapon doesn't impose disadvantage on its attack rolls.

Actions

Multiattack. The redcap makes three attacks with its wicked sickle.

Wicked Sickle. Melee Weapon Attack: +6 to hit, reach 5 ft., one target. Hit: 9 (2d4 + 4) slashing damage.

Ironbound Pursuit. The redcap moves up to its speed to a creature it can see and kicks with its iron boots. The target must succeed on a DC 14 Dexterity saving throw or take 20 (3d10 + 4) bludgeoning damage and be knocked prone.

Spore Infested Giant Constrictor Snake

Huge beast, unaligned

Armor Class 12

Hit Points 60 (8d12 + 8)

Speed 30 ft., swim 30 ft.

STR	DEX	CON	INT	WIS	CHA
19 (+4)	14 (+2)	12 (+1)	1 (-5)	10 (+0)	3 (-4)

Skills Perception +2

Senses Blindsight 60 ft., Passive Perception 12

Languages --

Challenge 2 (450 XP)

Spore Infested. When the creature is struck by an attack that deals slashing or piercing damage, spores fill the air, heavily obscuring a 5 ft. radius around the creature

Actions

Bite. Melee Weapon Attack: +6 to hit, reach 10 ft., one creature. Hit: 11 (2d6 + 4) piercing damage.

Constrict. Melee Weapon Attack: +6 to hit, reach 5 ft., one creature. Hit: 13 (2d8 + 4) bludgeoning damage, and the target is grappled (escape DC 16). Until this grapple ends, the creature is restrained, and the snake can't constrict another target.

Spore Infested Giant Crocodile

Huge beast, unaligned

Armor Class 14 (natural armor)

Hit Points 85 (9d12 + 8)

Speed 30 ft., swim 50 ft.

STR	DEX	CON	INT	WIS	CHA
21 (+5)	9 (-1)	17 (+3)	2 (-4)	10 (+0)	7 (-2)

Skills Perception +2

Senses Blindsight 60 ft., Passive Perception 12

Languages --

Challenge 2 (450 XP)

Spore Infested. When the creature is struck by an attack that deals slashing or piercing damage, spores fill the air, heavily obscuring a 5 ft. radius around the creature

Hold Breath. The crocodile can hold its breath for 30 minutes.

Actions

Multiattack. The crocodile makes two attacks: one with its bite and one with its tail.

Bite. Melee Weapon Attack: +8 to hit, reach 5 ft., one target. Hit: 21 (3d10 + 5) piercing damage, and the target is grappled (escape DC 16). Until this grapple ends, the target is restrained, and the crocodile can't bite another target.

Tail. Melee Weapon Attack: +8 to hit, reach 10 ft., one target not grappled by the crocodile. Hit: 14 (2d8 + 5) bludgeoning damage. If the target is a creature, it must succeed on a DC 16 Strength saving throw or be knocked prone.

Treant

Huge plant, chaotic evil

Armor Class 16 (natural armor)

Hit Points 138 (12d12 + 60)

Speed 30 ft.

STR	DEX	CON	INT	WIS	CHA
23 (+6)	8 (-1)	21 (+5)	12 (+1)	16 (+3)	12 (+1)

Damage Vulnerabilities Fire

Damage Resistances Bludgeoning, Piercing

Senses Blindsight 60ft, Passive Perception 13

Languages Common, Druidic, Elvish, Sylvan

Challenge 9 (5,000 XP)

Spore Infested. When the creature is struck by an attack that deals slashing or piercing damage, spores fill the air, heavily obscuring a 5 ft. radius around the creature

False Appearance. While the treant remains motionless, it is indistinguishable from a normal tree.

Siege Monster. The treant deals double damage to objects and structures.

Actions

Multiattack. The treant makes two slam attacks.

Slam. Melee Weapon Attack: +10 to hit, reach 5 ft., one target. Hit: 16 (3d6 + 6) bludgeoning damage.

Rock. Ranged Weapon Attack: +10 to hit, range 60/180 ft., one target. Hit: 28 (4d10 + 6) bludgeoning damage.

Animate Trees (1/Day). The treant magically animates one tree it can see within 60 feet of it. These trees have the same statistics as a treant, except they have Intelligence and Charisma scores of 1, they can't speak, and they have only the Slam action option. An animated tree acts as an ally of the treant. The tree remains animate for 1 day or until it dies; until the treant dies or is more than 120 feet from the tree; or until the treant takes a bonus action to turn it back into an inanimate tree. The tree then takes root if possible.

Map 3a: The Spore Swamp



Map 3b: Summer's Lilly

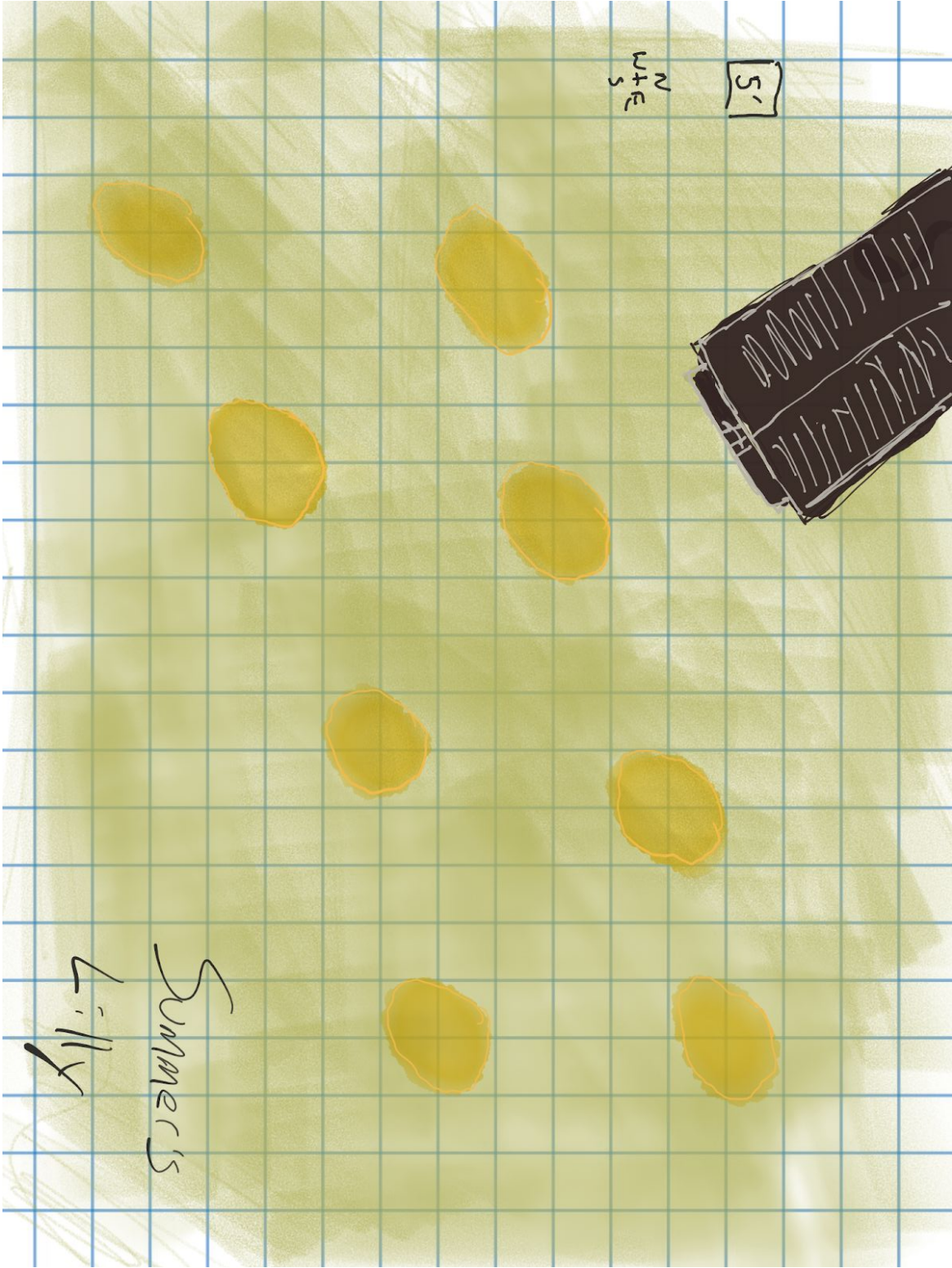

Map 4: The Clearings

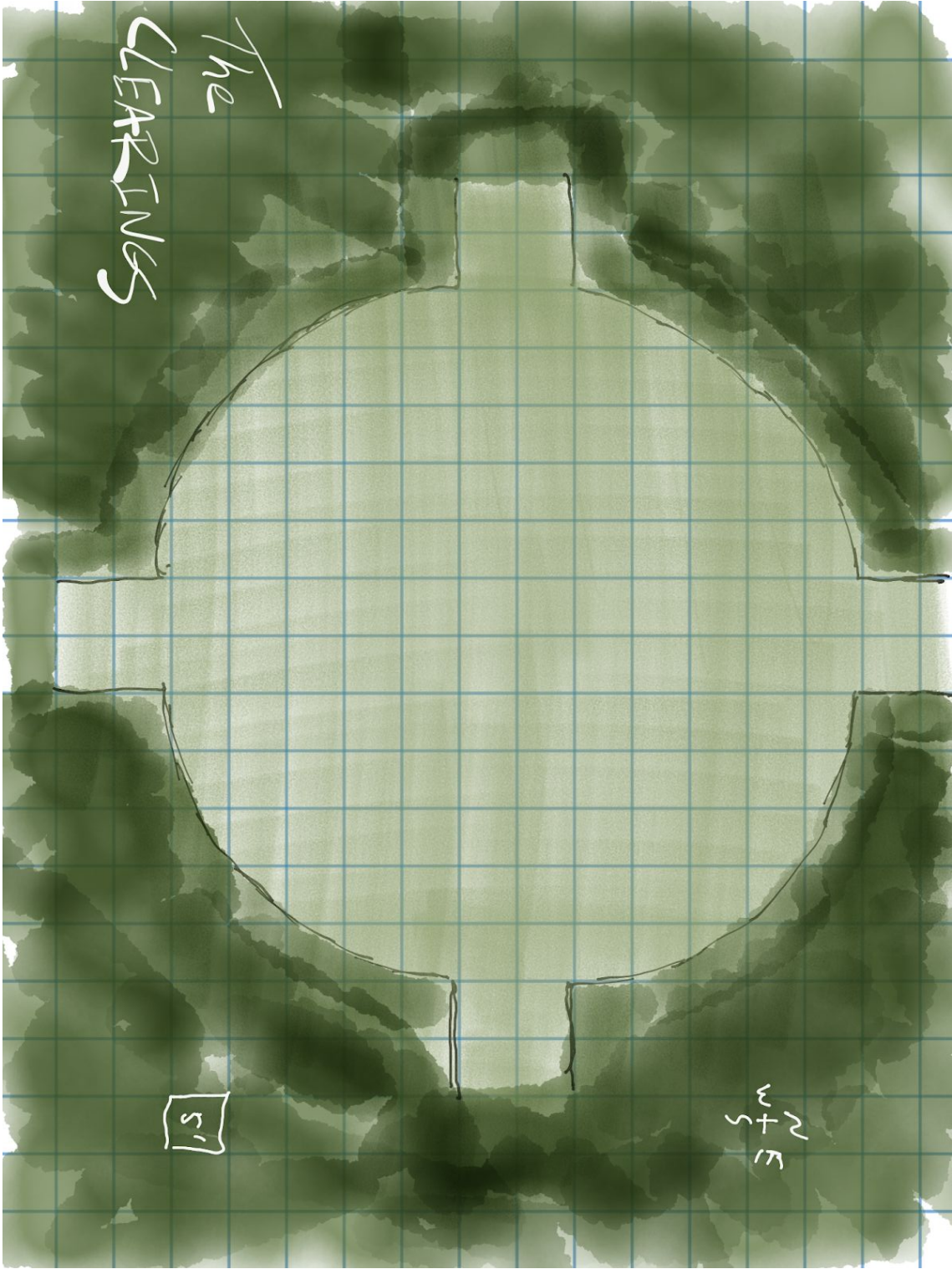

Not for resale. Permission granted to print or photocopy this document for personal use only.
DDAL-CCC-Tarot02-03 To Boldly Go

Appendix. DM Handout Maze Key

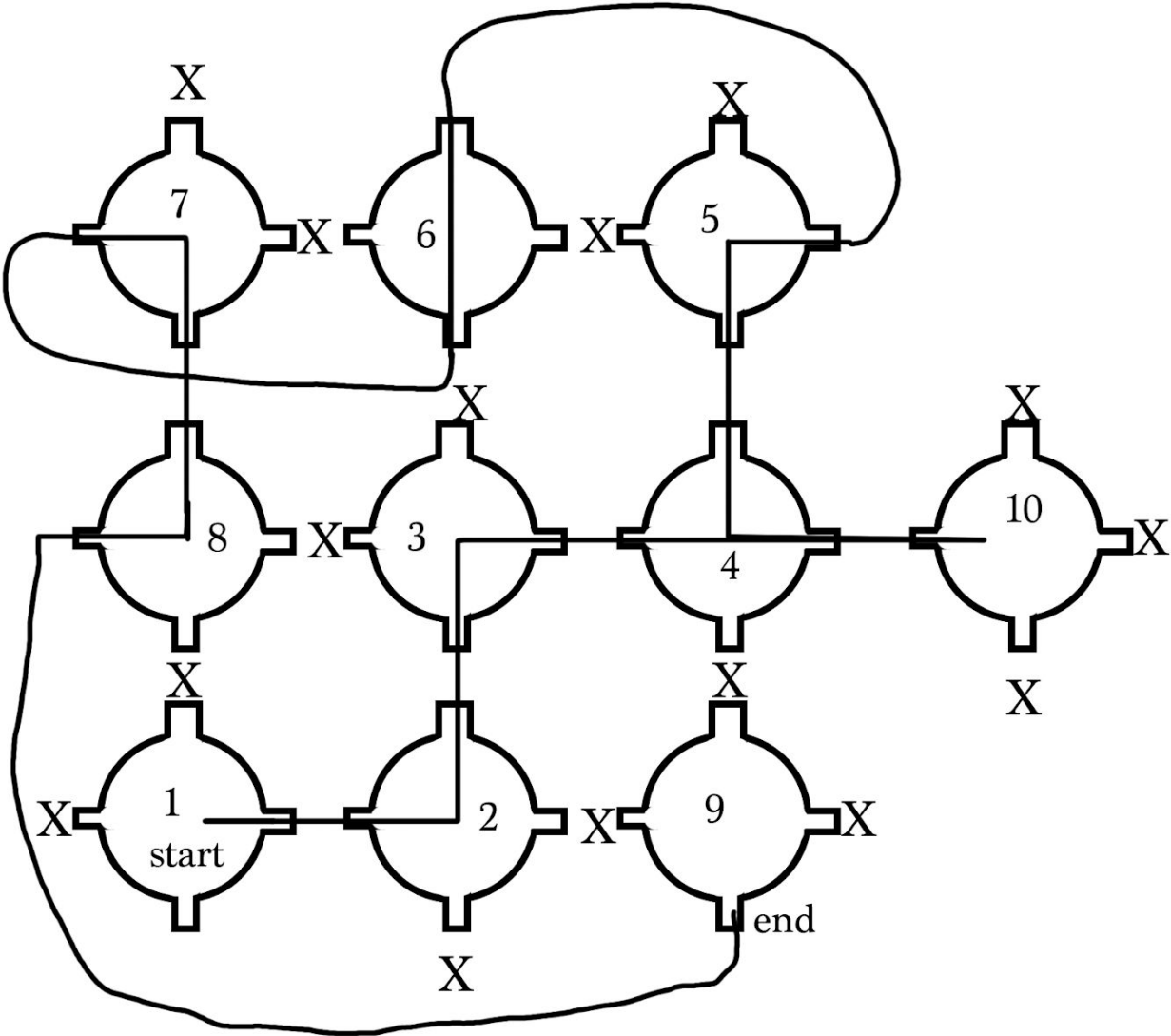

Appendix. Tarot Readings

d8	Card	Upright (even roll)	Inverted (odd roll)
1	The Magician	The Magician suggests your particular talents or resources will be needed in the near future. You should seek to tap into your full potential.	You have come to overestimate your own ability. Someone will no doubt seek to use your ignorance to manipulate you into foul ends in the near future. You must not be deceived!
2	Star	The Star is a card of renewal. This card is the call of destiny that motivates you or compels you to go on. Your desire is not in vain as you will ultimately find what you are yearning for.	This card reveals you are becoming disengaged or uninspired with your life. You will encounter a test of faith in the future. Overcome it and it will strengthen you.
3	Justice	Justice reflects the search for truth. You need to know and speak the truth and perceive it in the words and deeds of others. Be fair and just with all and you will soon be able to detect dishonesty in yourself and others.	I sense dishonesty to yourself and others. It shows an unwillingness to understand the deeper meaning of why an event has occurred and shows that you are missing some opportunity for a greater understanding of yourself in life. You need to accept responsibility for your actions.
4	Temperance	Ah, excellent! You have clear purpose and are doing what is necessary to reach it. Be careful not to become impatient, timing and precision will be important.	An Inverted Temperance. This reveals you are lacking purpose in life. You should take time to reflect on what is necessary in your life to create purpose.
5	Strength	The Strength card represents inner strength and the power of one's spirit to overcome any obstacle. The meaning of the Strength Tarot card is about knowing that you can endure life's obstacles by drawing upon your inner strength and confidence.	Your inner strength and courage is lacking right now and you are feeling inadequate and vulnerable as a result. Return to the lesson of the Chariot, where you need to draw upon your willpower, focus and determination in order to overcome your obstacles and be victorious.
6	The High Priestess	The High Priestess. She represents enlightenment and divine wisdom. Hidden truths will be revealed to you soon. Use them wisely.	Beware! Hidden machinations work against you. Seek out the truth, demand it if you must, to avoid being blindsided.
7	Judgment	The Judgement card suggests that you have had a recent epiphany or an 'awakening' where you have come to a realisation that you need to live your life in a different way and you need to be true to yourself and your needs.	Reversed, the Judgement card suggests that you may be indulging yourself in doubt and self-judgement. Your deliberation is causing you to miss the new opportunities that await.
8	The Fool	The Fool is a card of potential and new beginnings. It is also a card of difficult decisions. You should believe in yourself and follow your heart no matter how crazy it may seem.	You are acting recklessly, failing to show proper regard for others. If you are not careful and do not become more mindful of others you may be taken advantage of.

Player Handouts 1: Magic Items

During the course of this adventure, the characters may find the following permanent magic item:

Auntie Helena's Wand (Wand of Paralysis)

Wand, rare (requires attunement by a spellcaster)

This item can be found in the *Dungeon Master's Guide*. The prickly gnarled piece of the corrupted Treant requires a drop of blood to activate. When a creature fails their saving throw, they envision themselves turning into a twisted, rotted tree.

Player Handouts 2: Story Awards

During the course of this adventure, the characters may earn the following story awards:

Touched by Fate Many Powers circle around Thentia, and the Moonsea searching for lost magical artifacts. For whatever reason, the Fates have chosen you to be involved.

The Magician:

(Upright) You listened to Widar's plea and decided to investigate Summer's Lilly. No doubt your skills will be needed in the future to help with what you saw.

(Inverted) You thought it best to listen to Karasht and head to where the spores were most concentrated. Believing that you can overcome anything, you made a decision without hesitation.